

WELCOME TO STARTUP CITY!

Launching an innovative product? Creating a new never-before-seen service?

Startup City at ISPCON is the place to let your ideas loose! The service provider community is looking to see what you have on the horizon. Get featured in this high-traffic pavilion on the industry's largest show floor **at a discounted package rate!**



Your \$2995 investment includes:

- turn-key kiosk space in the 20x20 pavilion
- header graphics with your company name/logo (as pictured)
- electricity for your kiosk (to run a computer, etc.)
- listing as an ISPCON exhibitor in the show guide, on the website and other pre-show promotional material as available
- one-slide advertisement in the Demo Theatre ad rotation (PowerPoint)
- two free conference passes for staff members
- one web ad in rotation on ispcon.com (your choice of cube or skyscraper)
- your logo included in one full-page show guide ad promoting Startup City (created by ISPCON)
- **three days of face time with the most qualified decision-makers in the industry!**

For just \$250, you can add an Internet drop (shared T-1) to your kiosk, a \$600 savings for kiosk participants only!

There's a **LIMITED NUMBER OF SPOTS** in the pavilion and hundreds of companies with something new to talk about. This outstanding opportunity will sell out, so act quickly and be the buzz at the show!

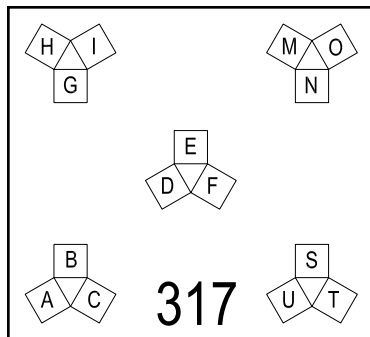

PLEASE NOTE:

- Only first-time ISPCON exhibitors may participate in Startup City.
- Participation in Startup City is limited to one event.

CALL US TODAY!

Nancy Moss: 408-850-9551
nmoss@thegoldengroup.net

WHAT WE'LL NEED FROM YOU:

- Completed company description form submitted via the Exhibitors Only section of the ISPCON website.
- Company logo as an Adobe Illustrator .EPS or .AI vector file, Illustrator version 9.0 or earlier

Both items due ASAP for maximum website exposure; no later than **September 2** for inclusion in the Show Guide and your kiosk header graphic. **Email logo to chorning@thegoldengroup.net**





The Definitive Event for Wired & Wireless ISPs

ISPCON FALL 2005: STARTUP CITY
OCTOBER 18-20
Santa Clara Convention Center
Santa Clara, CA

STARTUP CITY EXHIBITOR CONTRACT

Please complete and mail to: **ISPCON Fall 2005, c/o The Golden Group Inc.**
601 16th Street #C Unit 336 • Golden, CO 80401
FAX TO: 408-850-9551

The Exhibitor hereby submits this contract for exhibit/kiosk space at ISPCON Fall 2005 to The Golden Group (the "Producer") and hereby acknowledges and agrees to the terms and conditions set forth herein (including the reverse side hereof) and to the rules and regulations set forth in the Exhibitor Service Manual, as the same may exist today or as they may hereafter be updated or amended, and to such other rules and regulations as may from time to time be established by the Producer, all of which are incorporated herein by this reference. The Exhibitor further agrees that, upon acceptance of this Application by the Producer, this Application shall become a legally binding contract, enforceable against the Exhibitor in accordance with its terms.

1. EXHIBITOR INFORMATION:

Company Name: _____ Listing (as you want it in the Show Guide): _____
Main Contact: _____ Title: _____
Direct Phone: _____ Main Phone _____ Direct Fax: _____
Address: _____ City: _____
State/Province: _____ Zip/Postal Code: _____ Country _____ URL: _____
PRE-EVENT LOGISTICAL CONTACT EMAIL (REQUIRED): _____

2. BILLING CONTACT INFORMATION:

Company Billing Contact: _____ Title: _____ Phone: _____
Address (if different from above): _____ City: _____ State/Province: _____
Zip/Postal Code: _____ Country: _____ Direct E-Mail (Required): _____ Fax: _____
Purchase Order Number Required? Yes No If yes, P.O. Number: _____

3. PAYMENT TERMS: Payment is due July 15, 2005. In the event the Exhibitor cancels on or before July 15, 2005, all or part of the Exhibit space contracted for hereunder, the Exhibitor shall pay to the Producer a cancellation fee equal to 50% of all monies due. In the event the Exhibitor cancels after July 15, 2005, all or part of the Exhibit space contracted for hereunder, the Exhibitor shall pay to the Producer a cancellation fee equal to 100% of all monies due.

4. STARTUP CITY PACKAGES (SELECT ONE)

KIOSK SPACE ONLY: The rent for basic kiosk space inside this 20x20 space (#517) on the ISPCON Fall show floor is **\$2995.00 US**. This package includes: full-standing kiosk, (see diagram provided) customized header graphic, carpet and electricity. (Exhibitor must provide laptop computer, screen and/or any further display items to be used on this kiosk.)

1st Choice Kiosk (letter): _____ 2nd Choice Kiosk (letter): _____

ADD INTERNET CONNECTION:

This option will provide a shared T-1 connection for your kiosk. (Add \$250.00 to package price)
Total price 3245.00 US.

Although the Producer will consider requests for specific kiosk placement, no assurances can be given that the Exhibitor will be assigned the specific space requested. The undersigned hereby expressly represents and warrants that he/she is duly authorized to execute this binding contract on behalf of the Exhibitor named above and acknowledges that he or she has read and accepts all the terms on the reverse of this contract.

Authorized Signature: _____ **Date:** _____

Name (Printed) : _____ Title: _____

SEE IMPORTANT TERMS ON REVERSE

PLEASE INITIAL _____

5. LOCATION OF EXHIBIT SPACE. ISPCON Fall 2005 will be held at the Santa Clara Convention Center. All measurements and kiosk specified layouts shown on the floor plan are as accurate as possible. The Producer reserves the right to make such modifications and changes to kiosk location assignments and to the location of the full 20x20 space as may be necessary to adjust the floor plan at any time to meet the needs of the Producer, exhibitors and exhibits. The Producer reserves the option, in the event of any emergency or other circumstances beyond its reasonable control, to either substitute comparable exhibit space or to refund the total rent paid hereunder.

6. EXHIBITION MANAGEMENT. The Producer reserves the right to render interpretations and to establish such further rules and regulations it may deem necessary for the general success of the Exhibition. The Producer further reserves the right to decline, prohibit or expel any exhibit, which, in its sole judgment, is in poor taste or is out of character with, or reflects poorly upon, the Exhibition or is in violation of the terms of this contract or any applicable law, rule, or regulation.

7. EXHIBITOR SERVICE MANUAL. The Producer will furnish an Exhibitor Service Manual prior to the exhibition which will include specifications for drayage, labor requirements, labor rates, electricity, lighting, water, carpeting, furniture, telephones, food and beverage service, etc.

8. EXHIBIT SPACE EQUIPMENT AND SERVICE INFORMATION. The Exhibitor agrees to be bound by the rules and regulations as may be established from time to time by the Producer or as set forth in the Exhibitor Services Manual, or otherwise, and to abide by all applicable rules as set forth in the contracts of labor unions whose jurisdiction apply at the Exhibition. The Producer will furnish the Exhibitor with the name of an exhibit service contractor prepared to furnish all services customarily required within a reasonable time prior to the commencement of the Exhibition. The Producer assumes no responsibility or liability for any services performed or materials delivered by such contractor. Complete shipping instructions and information regarding furniture rental, electrical work, telephone installation, plumbing, labor for erecting and dismantling exhibits, drapery, etc. is contained in the Exhibitor Service Manual. A service desk will be maintained in the exhibit area.

9. INSTALLATION AND REMOVAL TIME. The specific times for installation and dismantling of exhibits shall be set forth in the Exhibitor Service Manual, subject to change at the discretion of the Producer. No other times are allowed.

10. EXHIBIT DATES. The Exhibit portion of ISPCON Fall 2005 will be held October 18-20, 2005 at the Santa Clara Convention Center. The Producer reserves the right to change exhibit hours and/or to change the number of days or dates of the Exhibition as it may seem desirable.

11. COMPETITIVE EVENTS. The Exhibitor shall not, during the Exhibition and the two-day period before the first day of any conference and/or exhibition produced by the Producer, conduct, Producer, or be affiliated with, within 25 miles of said conference or exhibition(s), any functions, classes, seminars, exhibits, or similar activities (hereinafter "functions") for more than 20 people which is similar to, competitive with or complementary to, any functions, classes, seminars, exhibits or other activities at the Exhibition, other than (i) the exhibit provided for in this contract, or (ii) those functions approved by the Producer in writing and held at a location specifically authorized by the Producer.

12. CANCELLATION. (A) In the event the Exhibitor cancels all or part of the exhibit space contracted for hereunder, the Exhibitor shall pay to the Producer a cancellation fee equal to all monies due as determined by the Payment Terms on the front of this contract. However, in no event shall the cancellation fee be less than one third of the total value of the purchase. Any cancellation fee is due at the time of cancellation. Whenever the payments already made by the Exhibitor to the Producer hereunder shall exceed the cancellation fee payable, the Producer shall refund such excess to the Exhibitor. Except for such excess, a payments made to the Producer under this contract shall be deemed fully earned and non-refundable. The cancellation fees described above are paid as liquidated damages and not a penalty. Exhibitor acknowledges that any cancellation will cause Producer to sustain significant damages that cannot be precisely ascertained at contract time.

(B) If the exhibit space is not occupied by the Exhibitor by 2:00pm on Tuesday, October 18, the Exhibitor shall be deemed to have canceled the exhibit space contracted for, and the Producer shall have the right to use such space as it deems appropriate and the Exhibitor shall pay to the Producer all amounts which would have been due, under the terms of subsection (a) above as if the Exhibitor had cancelled the contract as of such date.

(C) If the Exhibitor fails to make full payment when due under the terms of the contract, the Producer may terminate this contract and the Exhibitor shall be responsible for payment to the Producer of all amounts which would have been due the Producer, under the terms of subsection (a) above as if the Exhibitor had canceled this contract as of the date of such failure of payments. (b) Except as the Exhibitor's obligations to pay rent may be reduced in accordance with the terms set forth in subsection (A) above, the Exhibitor shall be responsible for payment of the exhibit space total rent whether the Exhibition is canceled, delayed or relocated, in whole or in part as a result of a riot, strike, civil disorder, act of war, act of God, or any other cause of any kind whatsoever not within the Producer's reasonable control. (D) The exhibitor shall be responsible for all collection costs and legal fees for any balance that is placed for collections.

13. RIGHT OF OFFSET. The Producer shall have the right to offset the amount of any obligation due and owing to the Producer from the Exhibitor against any obligations at any time due and owing to the Exhibitor by the Producer, whether under this contract or under any other contract arrangement or understanding between the Producer and the Exhibitor. Exhibitor is subject to Producer's standard credit terms and policies and Producer may apply any amounts received from Exhibitor to any other outstanding balances due to Producer.

14. USE OF EXHIBIT. The Exhibitor shall provide adequate staff for maintenance and operation of its exhibit during all exhibit hours. If the Exhibitor contracts basic space, the exhibitor shall provide carpet or other suitable floor covering for its entire exhibit space during all exhibit hours. All demonstrations or other promotional activities, including distribution of promotional material, shall be confined to the limits of the exhibit space. Sufficient space must be provided within the exhibit space for the comfort and safety of persons watching demonstrations and other promotional activities. The Exhibitor is responsible for keeping the aisles near its exhibit space free of congestion caused by demonstrations or other promotions. The Exhibitor shall not assign, sublet or share the exhibit space without the express written consent of the Producer. The Exhibitor shall display only goods manufactured or sold in the ordinary course of its business and that are related to the Exhibition. No individual, firm or organization not assigned exhibit space shall

solicit business within the exhibit area. No exhibit may exceed eight (8) feet in height without the express written permission of the Producer. In no case may the height along the side dividers exceed three (3) feet in the frontal three (3) feet of booth. No portion of any exhibit space sign or carpeting may extend over or beyond assigned floor space. Interference with the light and space of other exhibitors is prohibited. Display material exposing an unfinished surface to neighboring exhibit spaces is not permitted and must be finished at the Exhibitor's expense. The Producer reserves the right to perform such finishing at the Exhibitor's expense. The Exhibitor's booth and/or exhibit shall not intrude or interfere with the use of any adjacent exhibit area. The Producer reserves the right to restrict, segregate or relocate exhibits which, because of noise, method of operation, materials or any other reason, become objectionable. In the event of any such restriction or removal, the exhibitor shall have no claim against the Producer based upon any such restriction or removal. If the Exhibitor utilizes music (for example, from tape, record, CDs, audio-visual presentations, live entertainment or radio speakers), the Exhibitor shall first obtain written permission from the owner for the use of that music as required by applicable laws. Exhibitor shall comply with all applicable laws, rules and regulations that pertain to its exhibit.

15. TAXES AND LICENSES. The Exhibitor shall be solely responsible for obtaining any licenses, permits or approvals required under local or state law applicable to its activity at the Exhibition and for obtaining any tax identification numbers and paying all taxes, license fees or other charges that shall become due to any governmental authority in connection therewith.

16. EXHIBIT SAFETY. The Exhibitor hereby represents and warrants to the Producer that the Exhibitor has taken steps reasonably necessary to ensure that sound engineering and structural integrity of its exhibit design and the proper construction and safety of the exhibit itself, as erected, including obtaining the certification or a registered structural engineer if reasonably available. The Exhibitor accepts sole responsibility for any personal injury or property damage that may result directly or indirectly from the collapse of its exhibit or any portion thereof or the existence of any other unsafe condition at its exhibit. The Exhibitor hereby agrees to indemnify and hold harmless the Producer, the owner and manager of the exhibition facility, and others lawfully on the exhibit floor, from and against any claim, loss, liability or damage suffered as a result of the Exhibitor's installation, use, construction or maintenance of an unsafe exhibit, and the Exhibitor further represents and warrants that it has obtained adequate insurance to cover its potential liability hereunder. The Exhibitor will furnish the Producer with the engineering certificate and/or insurance certificates evidencing the coverage described herein upon request prior to or during the Exhibition.

17. LIMITATION OF PRODUCER'S LIABILITY. Neither the Producer, nor any of its affiliates, agents or representatives shall have any liability whatsoever to the Exhibitor for any loss, expense or damage to the Exhibitor, its guests, invitees or any of their property, relating to or arising out of the acts of any participant, visitor or other invitee of the Producer, other than for the Producer's failure to perform its obligations hereunder. Under no circumstances shall the Producer have any liability for lost profits or other special, incidental or consequential damages and the Producer's total liability hereunder shall in no case exceed the amount of the total rent actually received by the Producer from the Exhibitor. The Producer makes no representations or warranties with respect to the nature or volume of Exhibitor or Attendees. The Producer shall have no liability for any failure to perform its obligations hereunder where such failure to perform was due to any riot, strike, civil disorder, act of war, act of God, or any other cause of any kind whatsoever not within the Producer's reasonable control.

18. INDEMNITY. The Exhibitor hereby agrees to indemnify and hold harmless the Producer, its affiliates, and any of the officers directors, employees or agents from and against any and all loss, expense actions, claims, and damages, including, without limitation, reasonable attorney's fees, arising out of or caused by the Exhibitor's installation, construction, removal or maintenance of its exhibit, the Exhibitor's occupancy of use of the Exhibition premises or any part thereof or as otherwise caused by the Exhibitor, its agents, representatives, invitees or guests.

19. SECURITY AND PROPERTY INSURANCE. The Producer shall provide perimeter guard service during the hours the exhibit area is closed. However, the Exhibitor is solely responsible for the security of its own exhibit materials and the Exhibitor undertakes to obtain appropriate casualty insurance covering the same. All property of an Exhibitor is understood to remain in its sole care, custody, and control in transit to or from within the confines of the exhibit hall. The Exhibitor agrees to waive all rights of subrogation against the Producer, its officers, directors and employees.

20. LIABILITY INSURANCE. The Exhibitor shall obtain, at its own expense, adequate insurance, but in no event less than \$1million of comprehensive general liability insurance, including the so-called "broad form endorsement". Such insurance shall name the Producer, and its officers, directors, and employees as additional insured. The Exhibitor shall furnish, upon request, at or prior to the Exhibition, certificate of insurance evidencing said coverage.

21. CARE OF BUILDING AND EQUIPMENT. Neither the Exhibitor nor its representative or agents, shall injure or deface the walls or floors of the building, the exhibit spaces, or the equipment in the exhibit spaces. All materials used by the Exhibitor shall comply in all respects with all applicable laws, rules and regulations respecting fire safety and electrical equipment. Combustible materials or explosives are not permitted in the exhibit hall. The Exhibitor shall also comply with all reasonable requests of officials of the exhibit hall and the Producer with respect to the installation, conduct and disassembly of its exhibit.

22. MISCELLANEOUS. This contract contains the entire understanding of the parties with respect to the subject matter hereof and there are no other agreements, understandings, representations or warranties except as expressly set forth herein. This contract cannot be assigned, transferred, or sold by an Exhibitor. The rights of the Producer under this contract shall not be deemed waived except as specifically stated in writing signed by an authorized officer of the Producer. This contract and the rights of the parties hereunder shall be governed by and construed in accordance with the laws of the State of Colorado without regard to Colorado's choice of law rules. Any action brought to enforce the terms of this contract may be brought only in a court having a situs within the State of Colorado and the Exhibitor hereby expressly consents to the in personal jurisdiction of any such court. The Producer may, however, elect to enforce its rights in any proper jurisdiction. The Producer shall be entitled to recover the costs, including reasonable attorney's fees and/or collection fees, in any action brought to enforce this contract or its rights hereunder. The Golden Group, Inc. shall also be entitled to recover all accrued finance charges through the date of payment of the full amount of this contract.